

MESA PARA RUTEADORA POPULAR MODELO XL

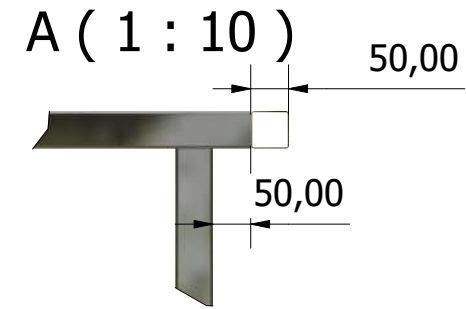

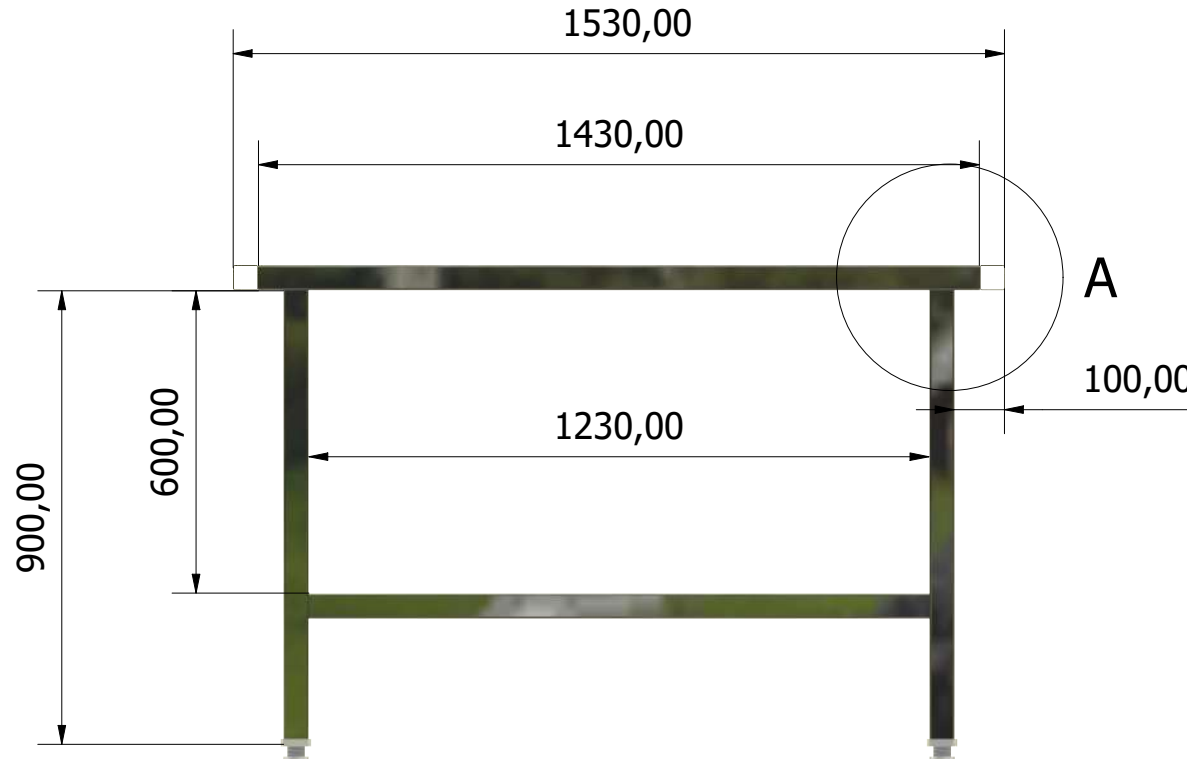

Tolerancia general	≥0.5	>3	>6	>30	>120	01	01	EN REVISIÓN			N/D		
	... 3	... 6	.. 30	.. 120	.. 400	Nº	Cant	Revisado	Material	Dimensión en bruto	Peso	Costo	
	±0.05	±0.1	±0.1	±0.15	±0.2	MESA PARA RUTEADORA(FRONTAL)						Proyecto Nº 01	
	±0.1	±0.2	±0.3	±0.5	MR01								
	Gruesa	±0.2	±0.3	±0.5	±0.8							LAMINA: 01	
Media	±0.1	±0.2	±0.3	±0.5	A4								
Fina	±0.05	±0.1	±0.1	±0.15	±0.2	PROYECTADO:		FECHA:	ESCALA:				
Calidad	Miguel Delgado		08-09-2023	1:15					

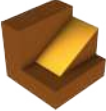
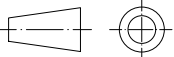

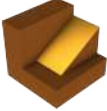
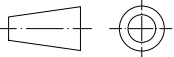
Tolerancia general	Calidad	≥0.5 ... 3	> 3 ... 6	> 6 .. 30	> 30 > 120	> 120 . 400	01	01	EN REVISIÓN		Dimensión en bruto	N/D	Costo						
	Fina	±0.05	±0.05	±0.1	±0.15	±0.2								Nº	Cant	Revisado	Material	Peso	
	Media	±0.1	±0.1	±0.2	±0.3	±0.5								MESA PARA RUTEADORA(DERECHA)					
	Gruesa	±0.2	±0.3	±0.5	±0.8	±1.2													
														FABRICACIÓN					LAMINA: 02
PROYECTADO: Miguel Delgado								FECHA: 06-09-2023	ESCALA: 1:15										

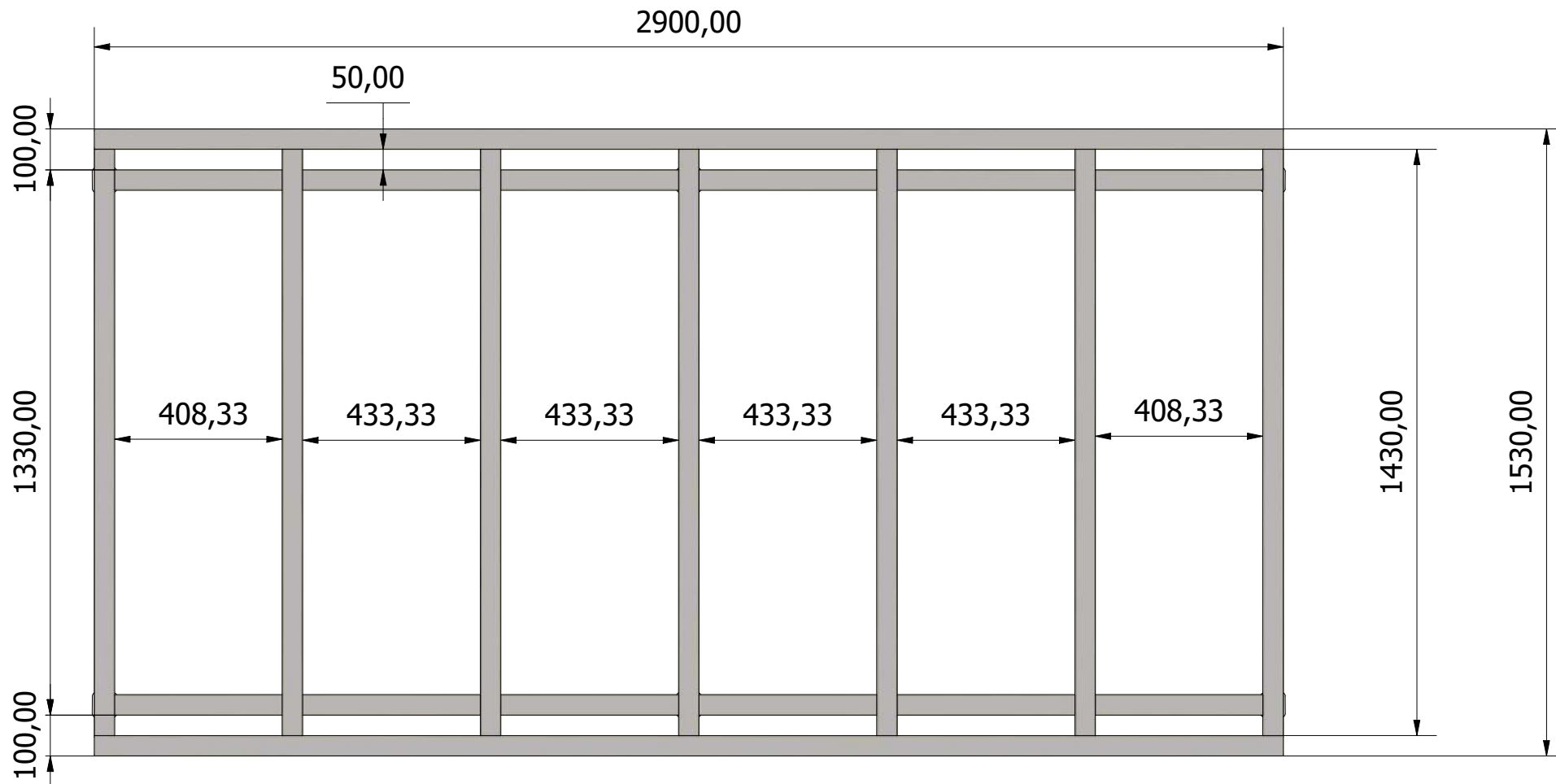

Tolerancia general	Calidad	Finis	Media	Gruesa	N°	Cant	Revisado	Material	Dimensión en bruto	Peso	Costo
	≥0.5	±0.05	±0.1	±0.2	01	01	EN REVISIÓN			N/D	
	... 3	±0.05	±0.1	±0.3							
	> 3	±0.05	±0.1	±0.3							
									MESA PARA RUTEADORA(SUPERIOR)		Proyecto N° 01 MR01
									FABRICACIÓN		LAMINA: 03 A4
									PROYECTADO: Miguel Delgado	FECHA: 08-09-2023	ESCALA: 1:15

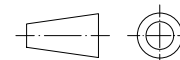
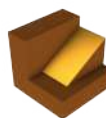

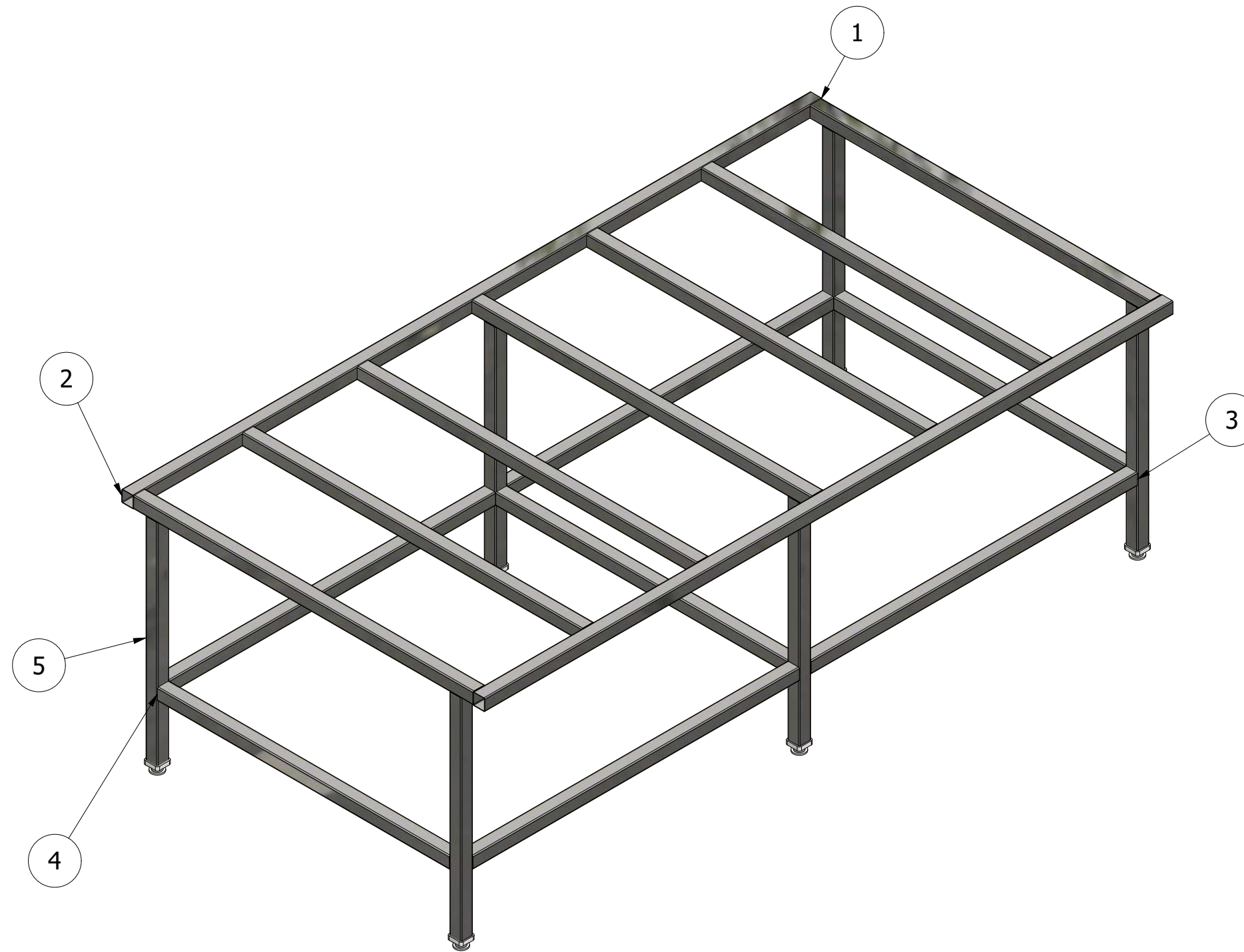

LISTA DE PIEZAS

ELEMENTO	CTDAD ELEMENTOS	MED. UNIDADES	Nº DE PIEZA
1	7	1430.000 mm	ISO 10799-2 - 50x50x2 - 1430
2	2	2900.000 mm	ISO 10799-2 - 50x50x2 - 2900
3	4	1375.000 mm	ISO 10799-2 - 50x50x2 - 1375
4	3	1230.000 mm	ISO 10799-2 - 50x50x2 - 1230
5	6	900.000 mm	ISO 10799-2 - 50x50x2 - 900

Tolerancia general	≥0.5	01	01	EN REVISIÓN			N/D	
	... 3	Nº	Cant	Revisado	Material	Dimensión en bruto	Peso	
	... 6	MESA PARA RUTEADORA(PIEZAS)					Proyecto Nº 01	
	> 3						LAMINA: 04	
	> 6	Fabricación					A3	
> 30	PROYECTADO: Miguel Delgado						FECHA: 08-09-2023	
> 120								